

# V1283 Series

## Intelligent IR Illuminator

**Infinova**<sup>®</sup>  
The Integrator's Manufacturer



### Professional Design

- Two stages of constant current circuit avoid LED away from instantly impulse impact when started
- A wide edge of silica gel waterproof circle and water stop line ensure excellent waterproof performance
- Twice direct cooling heat sink processing enable to increase the cooling coefficient and prolong the service life of the product
- Patent design hexagonal spherical light sensor more accurately responses ambient brightness and improves accuracy of automatic light control
- Flexible angle adjustable bracket can extend the illuminance range widely
- IP66 waterproof and dustproof housing available work at ambient temperature -40°C to 50°C

### Qualified Material

- Super power dot-matrix IR LED with strong light effect, long service life and low light decline feature
- High efficient twice optical lens processing achieves 90% of the luminous efficiency
- The housing adopts high thermal conductivity aluminum to enhance heat dispersion property
- Stainless steel bracket and screw ensure low maintenance

### Wide Range of Application

- Recommended for security at ports, railway systems, border, prisons, traffic LRP/ANPR, ITS as well as large public places surveillance

- 50,000 hours lifetime of LED
- Standard 3 years warranty

### Basic Function

- To improve performance of the weak light camera, thereby enhancing the picture effects at night
- Conventional night monitoring
- The function of video analysis at night
- Reduce signal noise and other image distortion
- Reduce the network bandwidth requirements
- Energy saving by power factor correction
- Reduce the equipment cost
- Lower cost of installing and wiring

The intelligent IR illuminator is a top performance, long service life LED light source of night illumination. Accurate constant current circuit drive not only develops excellent performance of LED but maintains whole product a super long life of 10 years.

It adopts Intelligent IR Technology, using the photocell to dim IR light, disperse and focus the light automatically. There is no blind area at less background light or over exposure of foreground at indoor or outdoor environment.

Deliver a constant brightness of IR light, intelligent control the output of LED, improving performance of the product and prolonging the lifetime of LED.

It's suitable for civil, industrial, and commercial surveillance.

## Technical specifications

LED type	30pcs 2W dot-matrix IR LED
Wavelength	850nm
Voltage	DC12V/AC24V
Power consumption	37W(850nm)
Day and night switch	Auto (build in photocell)
Cable	1.3M waterproof Cable
Mounting	Wall mounting "U" bracket
Temperature	-40°C to 50°C
Grade of protection	IP66
Color	Black
Housing	Aluminum
Panel	High light transmittance toughened glass
Net weight	DC12V: 2.75kg, AC24V:3.5kg
Gross weight	DC12V: 3.2kg, AC24V: 4kgs
Dimension	DC12V: 210*213*115.5mm, AC24V: 210*213*155.5mm
Packing dimension	DC12V: 290*250*170mm, AC24V: 300*260*200mm
Certificates	CE, FCC, ROHS

## Ordering information

V1283-200-2	Adaptive IR illuminator, 15° beam angle, 200m IR distance (850nm), IP66,DC12V
V1283-200-3	Adaptive IR illuminator, 15° beam angle, 200m IR distance (850nm), IP66,AC24V

IR distance is tested by Sony 1/3" CCD Camera 0.01 LUX.

## Dimensions (unit: mm)

### DC12V

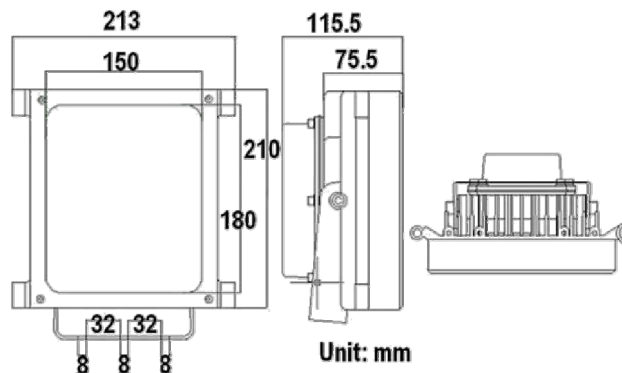

### AC24V:

